



Life Cycle Assessment of future management options for Danish MSWI fly ash

Final Report

Confidential

REG-no. DK 30 06 09 46



Table of Contents

Abbreviations	2
SUMMARY	3
PREFACE	6
1. INTRODUCTION	7
1.1. Goal and scope	7
2. METHODOLOGY	9
2.1. Functional unit	9
2.2. System boundaries	9
2.3. Modelling approach	9
2.4. Scenarios	10
2.5. Life Cycle Inventory	14
2.5.1. Technology data.....	14
2.5.2. Transportation distances	17
2.5.3. Direct emissions through leaching	18
2.5.4. Other processes.....	21
2.6. Uncertainty.....	21
2.6.1. Global Sensitivity Analysis.....	21
3. LIFE CYCLE IMPACT ASSESSMENT	22
3.1. Normalised impacts	22
3.2. Scenario comparison: contribution analysis	24
3.3. Uncertainty.....	29
3.3.1. Global sensitivity analysis.....	29
4. CONCLUSIONS.....	31
REFERENCES.....	32
A. APPENDIX.....	35
B. APPENDIX.....	44

Abbreviations

LCA	Life Cycle Assessment
L/S	Liquid-to-Solid
MSWI	Municipal Solid Waste Incineration
PE	Person equivalent
500y	500 years

Impact categories

EcoT	Ecotoxicity freshwater
EutrF	Eutrophication Freshwater
EutrM	Eutrophication Marine
EutrT	Eutrophication Terrestrial
GW	Climate change
HTc	Human toxicity, cancer effects
HTnc	Human toxicity, non-cancer effects
IR	Ionising radiation human health
OD	Ozone depletion
PM	Particulate matter
POF	Photochemical ozone formation, human health
RD	Depletion of abiotic resources, minerals and metals
RDfos	Depletion of abiotic resources, fossil
TA	Terrestrial acidification

SUMMARY

Conceptual framework

This report provides a Life Cycle Assessment (LCA) of selected scenarios for the treatment of Municipal Solid Waste Incineration (MSWI) fly ash in Denmark, in comparison with the current management system, i.e. shipping and utilisation outside Denmark (baseline scenario). The LCA was conducted by DTU Environment in the period January – April, 2019.

The purpose of the study is to provide a comparative assessment of the overall environmental impacts associated with four alternative treatment scenarios for MSWI fly ash with respect to a range of environmental impacts and taking into account expected transportation distances. The selected technologies do not aim to cover a full list of potential technologies available on the market, but rather mature technologies (both technically and commercially) currently operating full-scale in Europe. The considered technologies are:

- i. Disposal with utilization of fly ash for neutralization of waste acid (baseline scenario). The example process used is the NOAH process, Langøya Norway.
- ii. Encapsulation in cement resulting in lightweight aggregates used in concrete blocks. The example process used is the Carbon8 Aggregates Ltd.
- iii. Washing and Recycling: chemical extraction (with scrubber acid water) of valuable metals from the ash and the disposal of the remaining by-products. The example process used is the Fluwa process.
- iv. Washing and Recycling with salt recovery: the same technology described in point iii) is additionally recovering salts from the ashes.

Methodological framework

The LCA has been conducted according to the principles outlined in DS/EN ISO International Standards 14040 and 14044. The system boundaries include upstream processes and emissions to air/water/soil related to material and energy requirements for the assessed technologies, as well as substituted energy and products. Direct emissions related to the operation of the technologies and downstream emissions related to the handling of the individual technology outputs are included, too. In the case that the technology recovers materials, the system is credited with the avoided potential emissions that would have been otherwise necessary in order to produce these resources.

The functional unit is “treatment of MSWI fly ash including the management of the generated residues and products. The treatment of fly ash takes place in Denmark, except for the NOAH process that is carried out in Norway.” The reference flow is “1 metric tonne of MSWI fly ash”. The

selected time horizon is 500 years (500y). The geographical scope is Denmark and the temporal scope is the period 2020 – 2030.

None of the technologies investigated during this LCA is currently operating in Denmark, and the exact knowledge of technology consumptions is typically company sensitive and confidential. Accordingly, operational and technological parameters, as well as emissions to the environment via leaching and transportation distances were modelled through the use of probability distributions, based on available data and/or estimations. The uncertainty within the individual scenarios was propagated and the uncertainty brought by each single scenario parameter to the overall result uncertainty was calculated. The parameters mostly responsible for the scenario uncertainty were identified.

Findings and conclusions

The baseline scenario often presented the lowest burdens to the environment, but not necessarily. The Washing and Recycling scenarios performed better in the case of following impact categories: RD, EutrF and EutrT (and GW, but only when salt recovery was included also).

The Washing and Recycling scenarios showed lower impacts (or higher savings) than the scenario where fly ash is encapsulated in lightweight aggregates in the following impact categories: GW, RD, HTnc, EcoT, EutrF and EutrT (and EutrM, but only when salt recovery was included also). In the case of PM, the scenario where fly ash is encapsulated in lightweight aggregates presented lower impacts than the Washing and Recycling scenarios. In the case of HTc, the relatively large uncertainty behind the long-term release of Cr from the lightweight aggregates made it difficult to define a simple ranking across the scenarios, although the average net impacts observed for the Washing and Recycling scenarios were lower than for the scenario where fly ash is encapsulated in lightweight aggregates.

In general, the impacts from the Washing and Recycling scenarios were slightly lower in the case of salts recovery, but they were very sensitive to the way that heat is assumed to be generated. The production of auxiliary materials had a relatively high impact to the individual impact categories, irrespective of the technology considered. On the other hand, the impact of the considered transportation processes were mostly negligible when compared with the other processes. In the case that the technology recovered materials, the avoided production of especially zinc concentrate, quicklime and sodium chloride (de-icing) resulted into important saved emissions to environment.

The toxicity impact categories (i.e. HTc, HTnc and EcoT) were the ones that showed the highest uncertainty in the results. In general, a large part of this uncertainty could be described by the uncertainty in leaching of a few key elements, i.e. Zn, Cr and Ni. If on one hand, the availability of



more material-specific leaching data could provide a more accurate information on the potential leaching behaviour of both the aggregates and the washed fly ash, on the other hand, it is worth noting that the modelling of long-term emissions through leaching is intrinsically highly uncertain.



PREFACE

This report provides a Life Cycle Assessment (LCA) of selected scenarios for the treatment of Municipal Solid Waste Incineration (MSWI) fly ash in Denmark, in comparison with the current management system, i.e. shipping and utilisation outside Denmark.

The included technologies do not represent an exhaustive list of potential options, but rather include selected technologies that are considered both technically and commercially mature and relevant for full-scale operation in Denmark.

The LCA was conducted by DTU Environment in the period January – April, 2019, using the EASETECH model developed by DTU Environment for the environmental assessment of waste management systems and environmental technologies. The LCA is part of work package n. 3 in the project “Future handling of fly ashes” (i.e. “Fremtidig håndtering af flyveaske”). The commissioner of the LCA is the project group associated with this project.

The LCA has been conducted according to the principles outlined in DS/EN ISO International Standards 14040 and 14044. The report is intended for internal use within the project group. The report has not undergone peer review outside the project group.

The report is confidential and only intended for internal decision support as part of a wider range of assessments aiming at investigating possible management options for MSWI fly ash in Denmark. The report does not aim to support comparative assertions intended to be disclosed to the public.

The choice of technologies reflects the results of an earlier screening carried out by Rambøll A/S, aiming at clarifying potentially available fly ash treatment technologies based on their technical maturity, commercial maturity and material recovery.

The report was prepared by Alberto Maresca and Thomas Astrup from DTU Environment.

DTU, April 2019

1. INTRODUCTION

1.1. Goal and scope

The purpose of the study is to provide a comparative assessment of the overall environmental impacts associated with four alternative treatment scenarios for Municipal Solid Waste Incineration (MSWI) fly ash with respect to a range of environmental impacts and taking into account expected transportation distances. The selected technologies do not aim to cover a full list of potential technologies available on the market, but rather mature technologies (both technically and commercially) currently operating full-scale in Europe. The considered technologies are:

- i. Disposal with utilization of fly ash for neutralization of waste acid. The example process used is the NOAH process, Langoya Norway. Short name: Disp&Neutr. This scenario represents the baseline situation.
- ii. Encapsulation in cement resulting in lightweight aggregates used in concrete blocks. The example process used is the Carbon8 Aggregates Ltd. Short name: Aggregate
- iii. Washing and Recycling: chemical extraction (with scrubber acid water) of valuable metals from the ash and the disposal of the remaining by-products. The example process used is the Fluwa process. Short name: Wash&Rec_NoSalt
- iv. Washing and Recycling with salt recovery: the same technology described in point iii) is additionally recovering salts from the ashes. Short name: Wash&Rec_SaltRec

The scenarios are further described in Section 2.4.

The study is carried out with the waste-LCA model EASETECH v.3.0.5 (Clavreul et al., 2014). The life cycle impact assessment methods were selected among those recommended by the European Commission (2011). The overall environmental impacts were calculated using both normalised impacts, e.g. PE / tonne fly ash (where PE indicates “person equivalent”), and characterised impacts, e.g. kg CO_{2eq} / tonne fly ash. The normalisation factors used in this LCA are presented in Table 1.

Table 1. Global normalisation factors for emissions and resource extraction in 2010, as defined in Laurent et al. (2013). The impact category “Depletion of abiotic resources” respects ILCD recommended characterization factors, and it has been split into “minerals and metals” and “fossil” according to the CML method updated in 2016 (<http://cml.leiden.edu/software/data-cmlia.html>).

Impact category	Acronym	Normalisation factor	Unit
Climate change	GW	8.10E+03	kg CO ₂ eq /person
Ozone depletion	OD	4.14E-02	kg CFC-11 eq /person
Human toxicity, cancer effects	HTc	5.42E-05	CTUh /person
Human toxicity, non-cancer effects	HTnc	1.10E-03	CTUh /person
Particulate matter	PM	2.76E+00	Kg PM2.5 eq /person
Ionising radiation human health	IR	1.33E+03	kBq U-235 eq /person
Photochemical ozone formation, human health	POF	5.67E+01	kg NMVOC eq /person
Terrestrial acidification	TA	4.96E+01	mol H ⁺ eq /person
Eutrophication Terrestrial	EutrT	1.15E+02	mol N eq /person
Eutrophication Freshwater	EutrF	6.20E-01	kg P eq /person
Eutrophication Marine	EutrM	9.38E+00	kg N eq /person
Ecotoxicity freshwater	EcoT	6.65E+02	CTUe /person
Depletion of abiotic resources, fossil	RDfos	6.24E+04	MJ /person
Depletion of abiotic resources, minerals and metals	RD	3.43E-02	kg Sb eq /person

2. METHODOLOGY

2.1. Functional unit

The functional unit is “treatment of MSWI fly ash including the management of the generated residues and products. The treatment of fly ash takes place in Denmark, except for the NOAH process that is carried out in Norway.” The reference flow is “1 metric tonne of MSWI fly ash”

2.2. System boundaries

The selected time horizon is 500 years (500y). The leaching from fly ash is expected to occur over a very long time-frame, possibly thousands of years (Astrup et al., 2006b). The selected 500y represent a practical compromise between the actual leaching times and the ability to describe these emissions within the limits of future uncertainties.

The geographical scope is Denmark and the temporal scope is the period 2020 – 2030. As already indicated by the functional unit, except for the Disp&Neutr technology (i.e. the baseline scenario), the alternative fly ash treatment technologies are assumed to operate in Denmark – although this is not the case currently.

The system boundaries include the consumption of energy and resources for treating and managing fly ash and the generated residues, emissions to air/water/soil, upstream processes (i.e. production of raw materials and electricity) and avoided processes (i.e. avoided production of primary materials). No upstream emissions related to the production of fly ash, acid scrubber water and sulphuric acid residues are accounted for, as these are considered to be waste by-products that are generated by other technologies independently of the fly ash management addressed in this assessment. In other words, a zero burden approach is applied here. The transportation of fly ash to the treatment plant is considered within the system boundaries.

The assessment did not include (i.e. cut-offs) the capital goods related to construction of new fly ash treatment technologies nor an analysis of the availability of treatment capacities (e.g. tonnes of fly ash that can be treated every year) for the individual technologies or new capacity requirements. Following common LCA practice, therefore, treatment capacities are assumed to adjust to the demand induced by each technology option.

2.3. Modelling approach

To reflect the effects of a decision between the current fly ash management in Denmark and alternative management options, the consequential LCA modelling approach is used. Multi-

functionality in the model is addressed by system expansion: the individual fly ash treatment technologies generate material flows that may displace other products in the market responding to changes in demand/supply induced by these secondary materials. For example, the use of lightweight aggregates made from fly ash is likely to induce a change in demand for gravel pit materials.

2.4. Scenarios

The following section describes the four alternative scenarios included in this study. The scenarios are described referring to their main technological features. However, as indicated in the scope section, the system boundaries also include upstream processes and emissions to air/water/soil related to material and energy requirements for the assessed technologies, as well as substituted energy and products. An evaluation of expected transportation distances for the main waste stream used as input to the technologies was carried out (indicated with a “T” in the figures and discussed in Section 2.5.2), whereas the transportation of auxiliary materials was based on European or global averages (i.e. “market processes” in the Life Cycle Inventory database Ecoinvent v3.5).

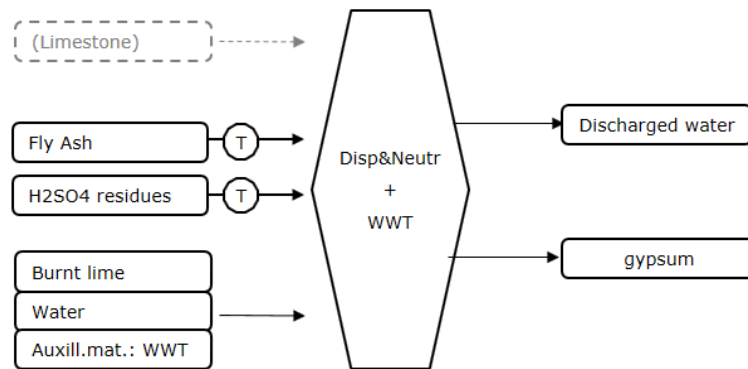

Figure 1. Scenario Disp&Neutr, with NOAH process. Materials flows are represented with squares, while processes with hexagons. Round figures represent transportation processes, which expected distance has been part of the scenarios analysis. Dashed lines indicates the avoided production of virgin raw materials. [T: transportation; WWT: wastewater treatment]

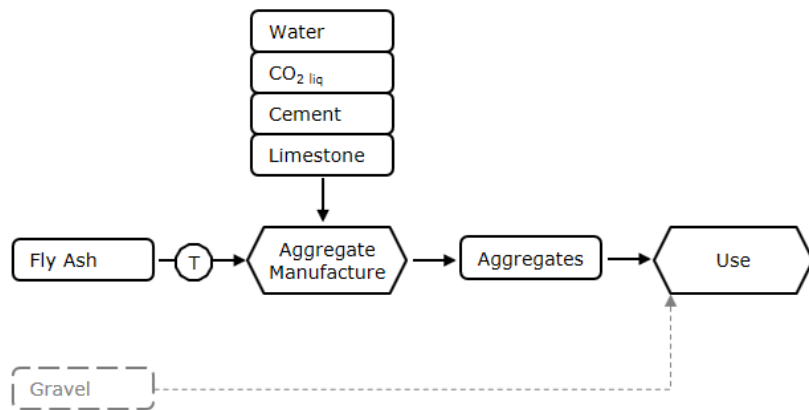

Figure 2. Scenario Aggregate, with Carbon8 Aggregates Ltd technology. Materials flows are represented with squares, while processes with hexagons. Round figures represent transportation processes, which expected distance has been part of the scenarios analysis. Dashed lines indicates the avoided production of virgin raw materials. [T: transportation]

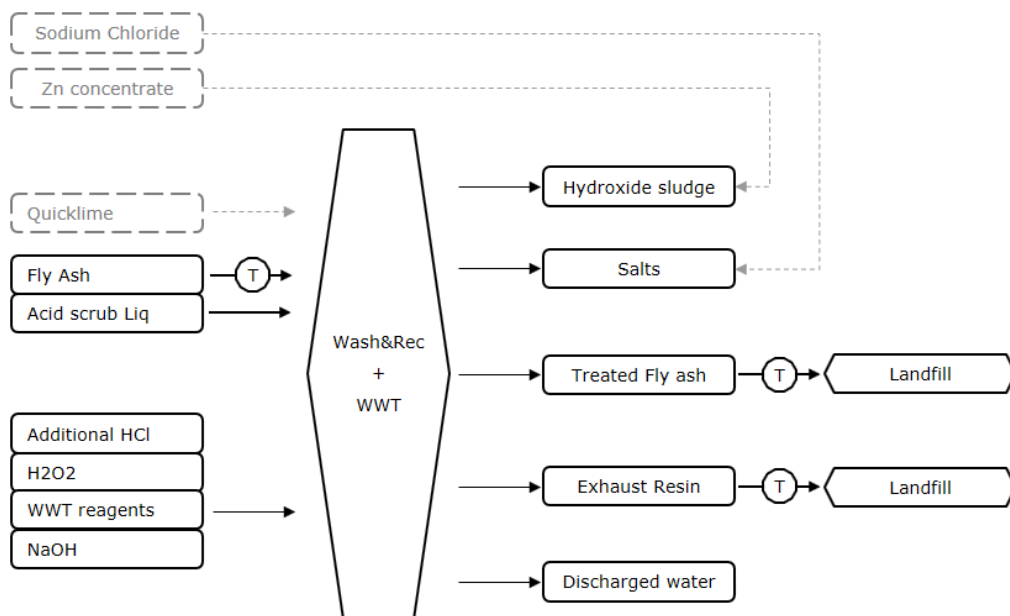

Figure 3. Scenario Wash&Rec, with Fluwa technology. Materials flows are represented with squares, while processes with hexagons. Round figures represent transportation processes, which expected distance has been part of the scenarios analysis. Dashed lines indicates the avoided production of virgin raw materials. [T: transportation; WWT: wastewater treatment]

Scenario Disp&Neutr

Currently, Danish MSWI fly ash is exported, either to Norway (where the fly ash can be disposed while being utilised for neutralization of waste acid, i.e. the NOAH process; see <https://en.langvik.noah.no/>) or to Germany (where the fly ash can be disposed while being utilised as a backfilling material in salt mines; see (Prognos AG et al., 2012)). The choice of Norway or Germany mainly relies on the transportation costs and material acceptance fees. In this LCA, the disposal of fly ash with utilisation for neutralization of waste acid was chosen to represent the Scandinavian alternative.

Danish fly ash is transported to Langøya, in Norway, and treated with the NOAH process. This treatment consists of a neutralisation process between liquid acid residues (i.e. mainly sulphuric acid residues from Kronos Titan AS, Fredrikstad, Norway), the alkaline MSWI fly ash and possibly other alkaline wastes (NGI, 2018). The use of MSWI fly ash avoids the use of natural limestone, i.e. otherwise used to neutralise the liquid acid residues. During the neutralization process, heavy metals (which represent a small percentage of the disposed material, i.e. up to 1-3%) are stabilised into new mineralogical forms with a relatively low water solubility or are bound onto iron hydroxides (NGI, 2018). The end-product of the neutralization process is a gypsum slurry that consolidates over time under the weight of new gypsum slurry settling on top of the older one. Geotechnical surveys on the consolidated gypsum slurry has described it as a standard consolidated silt (NGI, 2004). Figure 1 provides a schematic representation of the NOAH process.

Scenario Aggregate

Several examples of solidification processes for encapsulating MSWI fly ash into some kind of cement/concrete matrix are available in the literature. In this LCA, the solidification of fly ash in cement, resulting in lightweight aggregates, has been selected as an example. The technology is both technically and commercially mature, as indicated by the British company Carbon8 Aggregate Ltd (<https://c8a.co.uk/>).

Danish MSWI fly ash is assumed to be transported to a hypothetical Carbon8 Aggregate Ltd manufacturing plant in Denmark and used, together with other raw materials, to generate lightweight aggregates, which can be used in concrete applications for substitution of natural gravel. The aggregates are assumed to contain MSWI fly ash in the range of 30 – 50% (previous estimations from Rambøll A/S indicated a content of fly ash of ~40%).

The technology uses carbon dioxide (CO₂) to actively carbonate the fly ash before encapsulation as aggregates. As such, carbon dioxide is permanently sequestered by the fly ash during the carbonation process. At present, Carbon8 Aggregate Ltd uses liquid carbon dioxide, but future technology developments may allow the direct use of gaseous CO₂ coming from the exhaust flue gases of other industries. In any case, it is assumed that the carbon dioxide used by the process is a waste by-product of other production processes, i.e. it is free of upstream environmental burdens. On the other hand, the environmental burdens related to CO₂ pressurising and transportation are accounted for.

The use of lightweight aggregates containing MSWI fly is assumed to be restricted to specific application uses (note that at present, the use of such aggregates is not allowed for construction in Denmark) preventing direct human exposure to the potentially toxic substances in the aggregates.

Scenario Wash&Rec NoSalt

The potential extraction of valuable metals from fly ash, using the MSWI scrubber acid water as one of the reagents, has been investigated in a variety of lab- and full- scale studies. In this context, the Fluwa process represents a mature fly ash treatment technology operating full scale in Switzerland with extraction of valuable metals from the ash (Bühler and Schlumberger, 2010; Schlumberger et al., 2007). The technology is relatively well documented through scientific publications and technical reports.

The conventional treatment of acid scrubber water uses quicklime as a neutralising agent. The use of fly ash is expected to avoid the use of some of the quicklime, because of the intrinsic alkalinity of the material.

The Fluwa technology generates a metalliferous hydroxide sludge enriched in Zn, which can be processed by a regular Waelz kiln and used as a secondary Zn feedstock to the zinc smelting industry (i.e. avoiding the use of Zn concentrate). Other than the hydroxide sludge, the technology generates washed fly ash (typically landfilled) and wastewater (which treatment is included within the system boundaries of the scenario).

Scenario Wash&Rec SaltRec

Wash&Rec technologies generate a wastewater flow with a relatively high content of salts. The possibility of recovering these salts was investigated, assuming that this process would require an additional consumption of electricity and heat. It is assumed that the recovered salt would be a mixture of primarily sodium chloride, calcium chloride and potassium chloride, similarly to the results presented by the HALOSEP technology (i.e. “99 % of the

salt brine mixture is the three salts sodium chloride (NaCl), calcium chloride (CaCl₂) and potassium chloride (KCl)”; source: Miljøstyrelsen (2015)). This recovered salt is assumed to be used for road de-icing purposes, substituting the currently used sodium chloride.

2.5. Life Cycle Inventory

2.5.1. Technology data

In order to allow direct comparison across the different technologies, the composition of MSWI fly ash and acid scrubber water were assumed identical in all scenarios, as reported in Table A-1. Typical compositions of fly ash and acid scrubber water were estimated by Rambøll A/S, based on a range of observations from Danish MSWI plants. The composition of the sulphuric acid residue used in Scenario Disp&Neutr was assumed identical to the composition reported in NGI (2018) (average composition based on five observations during the period 2016-2017). Material and substance flow analysis of the individual technologies, including energy consumptions, were estimated based on publicly available data and/or estimated.

In the case of Scenario Disp&Neutr and Scenarios Wash&Rec, the composition of the discharged water was assumed to be equal to the maximum authorised composition, as defined in Miljødirektoratet (2014) for the NOAH technology and in ARC (2019) for the Amager Bakke discharged water.

The production of (marginal) electricity was assumed to come from a share of wind turbines (61%) and wood combustion (39%), as indicated by the Life Cycle Inventory database Ecoinvent v3.5 process “market for electricity, medium voltage_DK_2018_Consequential”. A similar share of wind turbines and wood combustion can be calculated from the European trend projections for Denmark (European Commission, 2016), based on the growing electricity sources (time scope: 2015-2035): wind turbines (56%) and combustion of biomass/waste (44%). Therefore, the use of the Ecoinvent process “market for electricity, medium voltage, DK, 2018, Consequential” was considered to be adequate.

The share of energy sources used to produce heat is site-specific, meaning that it is likely to vary across Denmark. For simplicity, and based on previous estimations, the production of this (marginal) heat was assumed to come from a share of biomass combustion (58%) and heat pumps (42%), irrespective of the specific Danish site.

Table 2 Amounts of raw materials and energy used by the fly ash treatment technologies, including outputs. The amounts are expressed per tonne of fly ash dry weight. [I): the assumed uncertainty aims to cover potential variability in the technology operating conditions; UD: uniform distribution]. Source: r: estimates from Rambøll A/S; a: based on Astrup (2008); b: based on Bösch et al. (2011); calc: calculated; f: based on Fellner et al. (2015).

Scenario Disp&Neutr, based on NOAH						
Material	Amount (average)	Unit	Source	Assumed Uncertainty	Assumed Distribution	Comment
INPUTS						
Fly ash	1	tonne				
Sulphuric acid residues	806	kg	r	± 25%	UD	I)
Quicklime	20	kg	r	± 50%	UD	I)
Water	900	kg	a	± 25%	UD	I)
Solvents and complexing agents	See Table A-2					
Electricity	13	kWh	a	± 25%	UD	I)
Diesel	0.6	L	a	± 25%	UD	I)
OUTPUTS						
Gypsum	~1280	kg	calc			
Discharged water	~1430	kg	calc			
AVOIDED MATERIALS						
Limestone	237	kg	calc	± 50%	UD	I), #

#: Assumption: Fly ash alkalinity in the range of 2-7 eq/kg; Limestone alkalinity: ~19 eq/kg

Scenario Aggregate, based on Carbon 8 aggregates LTD						
Material	Amount (average)	Unit	Source	Assumed Uncertainty	Assumed Distribution	Comment
INPUTS						
Fly ash	1	tonne				
Water	400	kg	r	± 40%	UD	I), §
CO ₂ liq	100	kg	r	± 40%	UD	I), §
Cement	240	kg	r	± 40%	UD	I), §
Limestone	900	kg	r	± 40%	UD	I), §
Electricity	70	kWh	r	± 25%	UD	I)
OUTPUT						
Aggregates	2500	kg	calc			
AVOIDED MATERIALS						
Gravel	4550	kg	calc	± 25%	UD	§§

§: the content of fly ash in the lightweight aggregates is assumed to vary in the range of 30-50%

§§: Assumption: 1 m³ of aggregates (i.e. ~900 kg/m³ from Gunning et al. (2011)) substitutes 1 m³ of gravel (i.e. ~1600 kg/m³)

Scenario Wash&Rec, based on Fluwa						
Material	Amount (average)	Unit	Source	Assumed Uncertainty	Assumed Distribution	Comment
INPUTS						
Fly ash	1	tonne				
Acid scrubber water	2050	kg	r	± 25%	UD	l)
Additional Hydrochloric acid (30%)	100	kg	b	± 50%	UD	l)
Processed water	1680	kg	r	± 25%	UD	l)
Hydrogen peroxide (50%)	84.5	kg	b	± 25% (based on f)	UD	l)
Solvents and complexing agents	See Table A-2					
Sodium hydroxide	24.1	kg	b	± 10% (based on f)	UD	l)
Electricity	146	kWh	b	± 5% (based on f)	UD	l)
OUTPUT						
Washed fly ash	1273	kg	r (estimated from b)			≈700 kg TS
Depleted resin (Hg adsorption)	0.5	kg	b			
Residual sludge (enriched in Zn)	262.5	kg	r (estimated from b)			≈105 kg TS (~17 kg Zn)
Discharged water	(3202.6)	kg	calc			
AVOIDED MATERIALS						
Quicklime	140	kg	b	± 50% ⌘	UD	l)
Zinc concentr.	22.5 *	kg	calc	± 50% ⌘	UD	l)

⌘: potential variability in the ash properties

*: Assumptions: 1 kg of zinc concentrate generates ~0.5 kg of primary zinc (based on Ecoinvent v3.5 data); ~70% of the Zn contained in the residual sludge is recovered by the Waelz process (assumption).

Salt Recovery (i.e. _SaltRec)						
Material	Amount (average)	Unit	Source	Assumed Uncertainty	Assumed Distribution	Comment
INPUTS						
Electricity	25	kWh	r	± 50%	UD	l)
Heat	2000	MJ	r	± 50%	UD	l)
OUTPUT						
Salts	290	kg	calc	± 50% ⌘	UD	l)
AVOIDED MATERIALS						
Sodium chloride	290	kg	assumption [▲]	± 50% ⌘	UD	l)

⌘: potential variability in the ash properties

▲: 1 kg of recovered salts is assumed to substitute 1 kg of sodium chloride used for de-icing purposes.

2.5.2. Transportation distances

Transportation distances between the MSWI plant and the fly ash treatment technologies were assumed, as reported in Table 3.

Table 3 Estimated distances to transport fresh fly ash to the treatment facility. [I): transportation distances are expected to vary depending on local conditions; UD: uniform distribution]

Scenario	Type of transportation	Distance (km)	Assumed distribution	Comment
Disp&Neutr	Lorry: Fly ash to the closest port	0-50	UD	I)
	Boat: Fly ash to Langøya (Norway)	450-550	UD	
Aggregate	Lorry: Fly ash to lightweight aggregate manufacture	10-75	UD	I)
Wash&Rec	Lorry: Fly ash to Wash&Rec technology	0-75	UD	I)
	Lorry: Hydroxide sludge to the closest port	0-50	UD	
	Boat: Hydroxide sludge to Boliden Odda (Norway)	900-1200	UD	
	Lorry: Washed fly ash to landfill	25-100	UD	

In general:

- The treatment of fly ash according to Scenario Disp&Neutr is carried out in Langøya, Norway. Danish MSWI fly ash is transported by a lorry to the closest port and then shipped to Langøya, similarly to the liquid acid residues. No further transportation occurs, because the materials are used onsite.
- In the case of Scenario Aggregate, it is assumed that the hypothetical manufacturing plant generating lightweight aggregates is located in the surrounding of the MSWI plant (lorry transportation); lightweight aggregates are then delivered to local concrete manufactures, but it is assumed that the net contribution of this transportation against the otherwise transported natural gravel is zero.
- In the case of Scenario Wash&Rec, it is assumed that two centralised Wash&Rec facilities are installed in Denmark, i.e. one in Zealand and one in Jutland. The Wash&Rec facilities are assumed to be installed at two relatively large and suitable MSWI plants. The two facilities can accept fly ash coming from the neighbouring MSWI plants, but there is no transportation of the acid scrubber water (it is assumed that the acid scrubber water generated onsite are sufficient). The generated washed fly ash and exhaust resins are sent to a landfill, whereas the metalliferous hydroxide sludge enriched in zinc is shipped to a Norwegian zinc smelter.

The influence of different transportation distances for the auxiliary materials used by the individual treatment technologies was not investigated during this LCA. Instead, global and European average transportation distances were assumed to take place, as defined by the selected “market processes” in the Life Cycle Inventory database Ecoinvent v3.5 (Wernet et al., 2016).

2.5.3. Direct emissions through leaching

Emissions to the environment through leaching were assumed to affect the groundwater compartment and their impact to the environment was calculated using ILCD recommended characterization factors. Due to the technological differences of the individual scenarios and the significant differences in documentation of emissions through leaching, estimations of leaching also differs for each scenario as indicated in the following paragraphs.

Scenario Disp&Neutr

During the NOAH process, the consolidation process of the gypsum slurry causes the excess pore water to be transported towards the less compacted (top) layers. The overall hydrological conditions at Langøya limits potential migration of pore water through the surrounding low-permeable rocks.

The excess pore water is collected and treated onsite by a local wastewater treatment plant; the treated wastewater is then discharged into the sea according to the limit values defined in Miljødirektoratet (2014). Because of the overall pore water dynamics, no leaching through the surrounding low-permeable rocks is assumed to occur.

It is assumed that the entire amount of excess of pore water is collected and treated onsite, corresponding to an emission through the treated wastewater discharge.

Scenario Aggregate

To our knowledge, there is no publicly available data describing the leaching behaviour of the lightweight aggregates generated by Carbon8 Aggregates Ltd, for example as a function of the Liquid-to-Solid (L/S) ratio or pH. At present, these aggregates have to comply with a range of geotechnical and environmental requirements (Carbon8 Aggregates Ltd, 2011), which also define the maximum leaching criteria allowed for the aggregates according to EN 12457-4:2002 (i.e. a batch leaching test carried out at the L/S ratio 10 L/kg, at the natural pH of the material with deionized water).

The use of lightweight aggregates made from MSWI fly ash is currently not allowed in Denmark. In the UK, these aggregates are used by concrete manufactures to make a variety of different products, e.g. blocks, ready mixed concrete and screed. As such, it may

be expected that the lightweight aggregates would be embedded in a kind of concrete matrix. However, the possibility of using the aggregates in unbound form, e.g. as a road sub-base material, cannot be excluded *a priori*, as currently there is no legislation in place in Denmark. Furthermore, by end-of-life of the primary application (e.g. aggregates in concrete) further utilisation may likely involve demolition, potential crushing and potentially secondary application as new aggregates or in unbound form. Depending on the actual application use, aggregates may experience different degrees of water contact, and therefore leaching.

To account for the variety of application uses of the aggregates over time, leaching from the lightweight aggregates was assumed to behave according to the following uniform distribution:

- minimum value: the aggregates release as much as half of their maximum leaching requirements (Carbon8 Aggregates Ltd, 2011). This situation aims to represent the case where the aggregates experience a moderate contact with water over the coming 500y.
- maximum value: the aggregates are assumed to be crushed and their release is calculated as the sum between the maximum leaching requirements defined for Carbon8 aggregates (Carbon8 Aggregates Ltd, 2011) and the average releases observed from carbonated MSWI fly ash during batch leaching tests carried out at the L/S 10 L/kg (Astrup et al., 2006c, 2006a; He et al., 2006; Li et al., 2007; Wang et al., 2016; Zhang et al., 2008, 2016).

As such, the assumed leaching distributions from lightweight aggregates represent different application pathways of the materials. Attempting to make specific predictions of the long-term cascade management of the lightweight aggregates is considered to be unjustifiable based on available information and lack of specific legislation.

The lightweight aggregates are assumed to replace natural gravel during their applications. To assess the net impacts of using lightweight aggregates instead of natural gravel, the leaching from natural gravel (Birgisdóttir, 2005) was subtracted from the leaching from lightweight aggregates. The net leaching from lightweight aggregates is summarized in Table A-3.

Scenario Wash&Rec

In the absence of detailed leaching data for washed fly ash generated by the Fluwa technology, the leaching behaviour of these materials was modelled based on column

experiments carried out on washed fly ash generated by the HALOSEP technology (Miljøstyrelsen, 2015). Column experiments were carried out on Danish MSWI fly ash samples generated at Vestforbrænding (four samples) and Amagerforbrænding (four samples). Cumulative releases from the column experiments were interpolated, by means of least squares fitting using a logarithmic function, and the leaching from washed fly ash was modelled as a function of the L/S ratio.

Differences in releases were observed when comparing the different samples, defining a potential “release window”, as a function of the L/S ratio. To account for this variability in leaching behaviour, the maximum and minimum releases (i.e. the “release window”) from washed fly ash were extrapolated at selected L/S ratios (the selection of these L/S ratios will be described shortly). These maximum and minimum releases were used to describe the leaching potential from washed fly ash in each of the selected L/S steps, assuming that any of the values within the observed “release window” was equally likely to occur (i.e. uniform distribution). The leaching from washed fly ash was modelled as the cumulative release over the selected L/S ratios.

Expected L/S ratios were calculated based on Danish conditions and using the formula:

$$L/S [L \cdot kg^{-1}] = \frac{I [\%] \cdot T [years] \cdot P [mm \cdot year^{-1}]}{\rho [kg \cdot m^3] \cdot h [m]}$$

where I represents the infiltration rate, T the number of years, P the annual Danish precipitation, ρ the bulk density of the material and h the height of the landfill that the infiltrating water is passing through. Table A-4 lists all the values used, as a function of the landfill age. Overall, the calculated L/S ratio for the landfilled washed fly ash over the coming 500y was 10.5 L/kg (± 2.8 L/kg).

It is assumed that the landfill cell is being filled within 2 years, and that the landfill leachate is actively collected with the first 70 years of landfill operation. Similarly to Damgaard et al. (2011), the efficiency of the leachate collection system is assumed to be at 95% during the first 20 years, at 80% during the following 20 years (where failure and clogging may start), and finally at 60% during the aftercare period (30 years). The selection of L/S ratios used to calculate the potential leaching from washed fly ash was calculated based on the aforementioned landfill time periods (i.e. 2y, 18y, 20y, 30y and 400y). The collected leachate is treated by a wastewater treatment plant, while the uncollected leachate is assumed to reach the groundwater. Table A-5 reports the net cumulative releases over 500y.

The wastewater generated at the Wash&Rec technology is treated onsite and it is assumed to be discharged into the sea according to the limit values defined for Amager Bakke (ARC, 2019).

2.5.4. Other processes

Upstream emissions related to the production of energy and the production (and transportation) of raw/auxiliary materials (in turn used by the individual fly ash treatment technologies) were estimated based on the Life Cycle Inventory database Ecoinvent v3.5 (Wernet et al., 2016). Emissions to the environment in connection with the processes downstream the fly ash treatment technologies (e.g. landfill operation) were also estimated based on Ecoinvent v3.5.

The full list of Ecoinvent v3.5 processes used within this study is reported in Table A-6.

2.6. Uncertainty

2.6.1. Global Sensitivity Analysis

Operational and technological parameters, as well as emissions to the environment via leaching and transportation distances were modelled through the use of probability distributions.

None of the technologies investigated during this LCA is currently operating in Denmark, and the exact knowledge of technology consumptions is typically company sensitive and confidential. Accordingly, rather than using normal distributions to describe the individual processes, the use of uniform distributions was preferred throughout this study (see e.g. Table 2 and Table 3).

The uncertainty within the individual scenarios was propagated following the approach of Bisinella et al. (2016), i.e. using the uncertainty contribution analysis. The uncertainty contribution analysis calculates the uncertainty brought by each single scenario parameter to the overall result uncertainty, therefore allowing the identification of the parameters mostly responsible for the scenario uncertainty.

3. LIFE CYCLE IMPACT ASSESSMENT

The following sections presents the results of the life cycle impact assessment, as the impacts associated with the management of 1 tonne of MSWI fly ash in Denmark. Negative values represent environmental savings (i.e. benefits), whereas positive values represent loads (i.e. impacts) to the environment.

In Section 3.1, normalised impacts are presented for all modelled impact categories to indicate the magnitude of the impacts relative to the impacts from an average person.

In Section 3.2, a range of selected impact categories are discussed in further details based on characterised impact values (results for the remaining impact categories are provided in Appendix B). The impact categories addressed in Section 3.2 represent those with i) the largest normalised impacts and ii) clear differences in performance across the three scenarios.

3.1. Normalised impacts

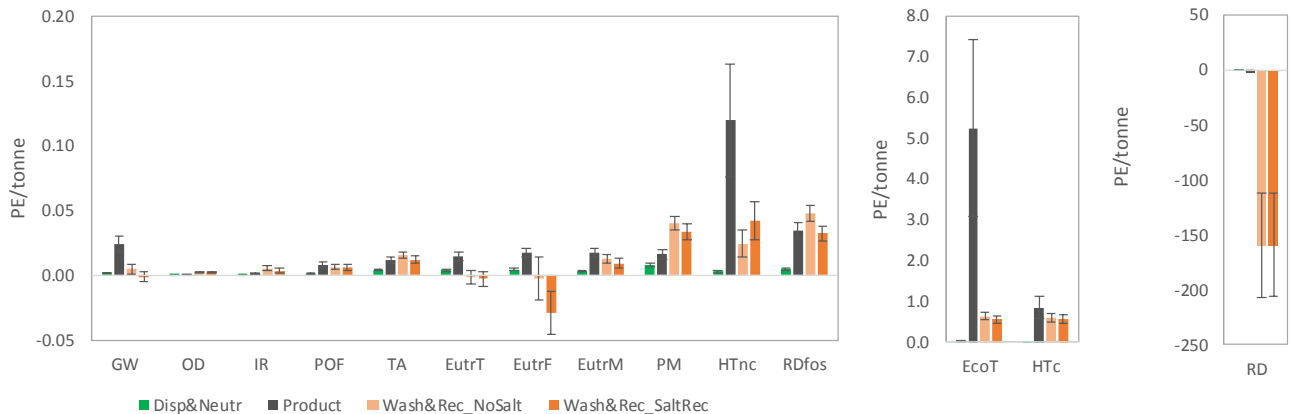

Figure 4. Normalised impacts of the four fly ash management scenarios. Negative values represent environmental savings (i.e. benefits), whereas positive values represent loads (i.e. impacts) to the environment. The net environmental impacts related to the individual scenarios are represented with a white diamond, accompanied by its standard deviation. [GW: Climate change, OD: Ozone depletion; HTc: Human toxicity, cancer effects; HTnc: Human toxicity, non-cancer effects; PM: Particulate matter; IR: Ionising radiation human health; POF: Photochemical ozone formation, human health; TA: Terrestrial acidification; EutrT: Eutrophication Terrestrial; EutrF: Eutrophication Freshwater; EutrM: Eutrophication Marine; EcoT: Ecotoxicity freshwater; Rdfos: Depletion of abiotic resources, fossil; RD: Depletion of abiotic resources, minerals and metals]

Although normalised impact results share the same unit (i.e. person-equivalent, PE), the individual impact categories should not be directly compared as they represent different types of impacts. In order to enable comparison, weighting (prioritisation) of the impact categories should be included

as well. This is not included in this report (i.e. implicitly assuming a unitary weighting). Figure 4 show the results of the normalised impacts in person equivalents per year, per tonne of fly ash being handled. The impact categories presented therein are divided into three groups, depending on the order of magnitude of the results.

Focusing on the difference between scenarios and within the individual impact categories, Scenario Disp&Neutr generally showed the lowest net environmental impacts, although the Wash&Rec scenarios performed better for some of the impact categories. Depending on the specific impact category, the highest net environmental impacts were shown either by Scenario Aggregate or by the Wash&Rec scenarios. In particular, Wash&Rec scenarios demonstrated considerably lower impacts than Scenario Aggregate in the case of “depletion of abiotic resources, minerals and metals” (RD), “ecotoxicity freshwater” (EcoT), “human toxicity, non-cancer effects” (HTnc), “eutrophication terrestrial” (EutrT), “eutrophication freshwater” (EutrF) and “climate change” (GW). To the contrary, Scenario Aggregate demonstrated considerably lower impacts than the Wash&Rec scenarios in the case of “particulate matter” (PM).

Based on these overall observations, the aforementioned impact categories were included in the discussion of the results in the following sections. Other impact categories were also included in the discussion, in the case of relatively large uncertainties in the results and less obvious rankings: “depletion of abiotic resources, fossil” (RDfos), “human toxicity, cancer effects” (HTc), “eutrophication marine water” (EutrM).

3.2. Scenario comparison: contribution analysis

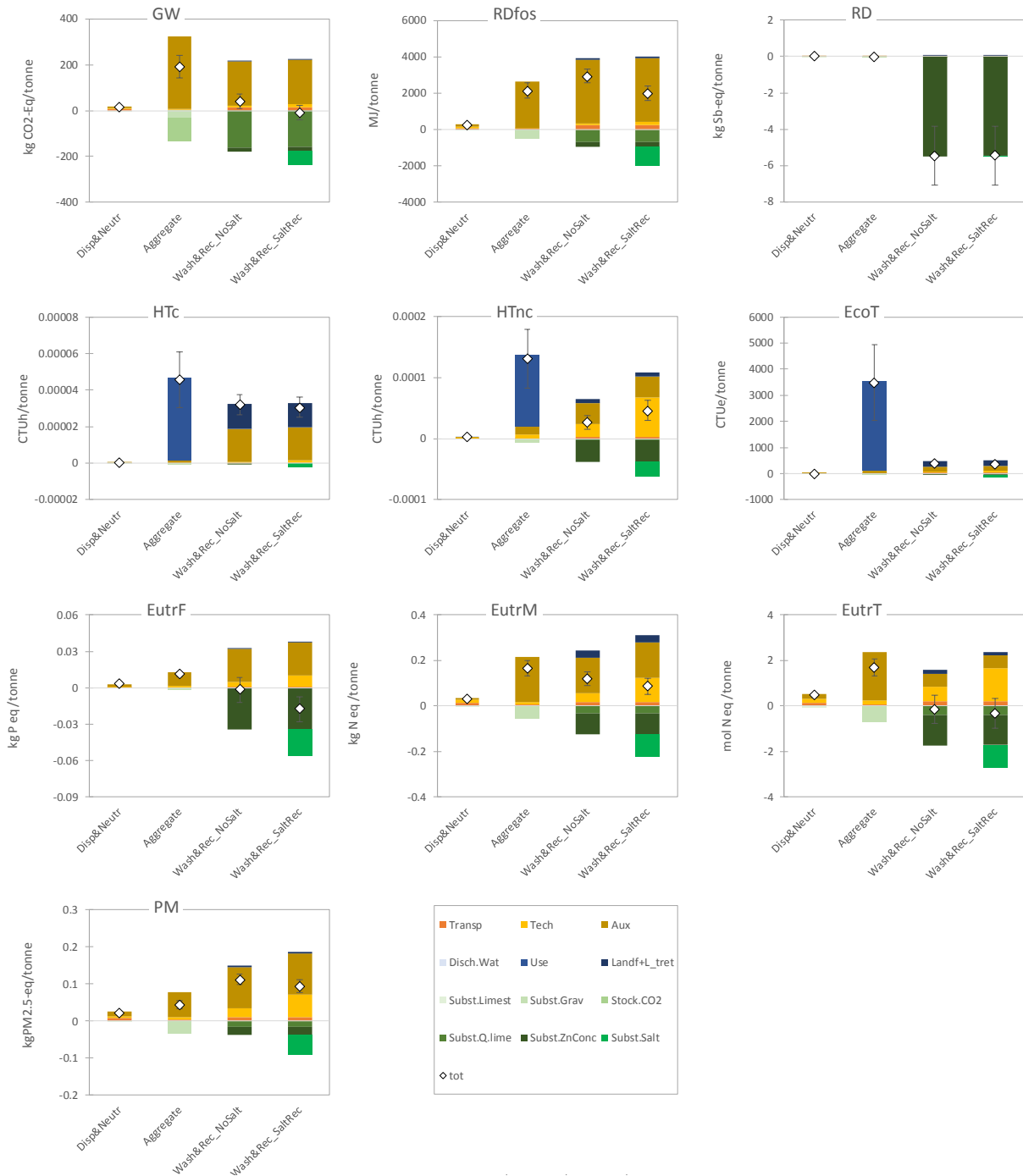

Figure 5. Characterised impacts of the four fly ash management scenarios. Negative values represent environmental savings (i.e. benefits), whereas positive values represent loads (i.e. impacts) to the environment. The net environmental impacts related to the individual scenarios are represented with a white diamond, accompanied by its standard deviation

Figure 5 reports the results of the process contribution analysis. In this section, the contribution analysis results are discussed per each individual impact category. A simple scenario ranking within the individual impact category is also included.

○ **Climate change (GW)**

- Ranking (low impact < high impact):

Wash&Rec_SaltRec < Disp&Neutr < Wash&Rec_NoSalt << Aggregate

- Aggregate:

The scenario provided net GW impacts. The main contributor to these net GW impacts was the production of auxiliary materials, namely cement (~68%) and liquid CO₂ (~30%). As such, the potential use of gaseous CO₂ coming from the exhaust flue gases of other industries, instead of liquid CO₂, would lower the net impacts; however, the overall environmental ranking of the scenarios would not change, as the savings related to stocked CO₂ and avoided use of natural gravel would not be able to overcome the impacts.

- Wash&Rec:

The use of fly ash as a neutralising agent to treat the acid scrubber water avoids the use (and upstream production) of some quicklime, which corresponds to relatively high CO_{2-eq} savings (i.e. ~1.15 kg CO_{2-eq}/ kg quicklime). These savings roughly counterbalanced the impacts related to the upstream production of the auxiliary materials used by the Wash&Rec technology (mainly hydrogen peroxide, i.e. ~57%, and sodium hydroxide, i.e. ~21%).

In the case of salt recovery, additional CO_{2-eq} savings due to the avoided production of virgin sodium chloride (de-icing) were shown, resulting into lower net impacts compared with the case of no salt recovery.

○ **Depletion of abiotic resources, fossil (RDfos)**

- Ranking (low impact < high impact):

Disp&Neutr << Wash&Rec_SaltRec ≈ Aggregate < Wash&Rec_NoSalt

- Aggregate:

The scenario provided net RDfos impacts. The upstream production of auxiliary materials largely overcame the savings related to the substituted gravel. The largest impacts were observed from the production of CO₂ liquid and cements, i.e. ~55% and 42% of the impacts from auxiliary materials, respectively. As such, the direct use of gaseous CO₂ coming from the exhaust flue gases of other industries, instead of liquid CO₂, would lower the net impacts from Scenario Aggregate, in turn potentially affecting the scenario ranking.

- Wash&Rec:
The scenario provided net Rdfos impacts. Similarly to Scenario Aggregate, the upstream impacts related to the production of the required auxiliary materials (mainly hydrogen peroxide, i.e. ~63%, and sodium hydroxide, i.e. ~25%) largely overcame the savings related to the substituted materials (quicklime and zinc concentrate). In the case of salt recovery, the savings due to the avoided virgin production of sodium chloride (de-icing) were able to lower the net Rdfos impacts to levels comparable to Scenario Aggregate.
- **Depletion of abiotic resources, minerals and metals (RD)**
 - Ranking (low impact < high impact):
Wash&Rec << Aggregate < Disp&Neutr
 - Aggregate:
The scenario provided net RD savings, primarily because of the avoided use of natural gravel. However, the calculated net savings were two orders of magnitude lower than the net savings showed by Scenario Wash&Rec.
 - Wash&Rec:
The scenario provided net RD savings, primarily due the avoided production of zinc concentrate. Based on the Ecoinvent v3.5 process “zinc-lead mine operation, GLO, 2018, Consequential”, zinc mining operations require the use of metal sulphides. The avoided use of these sulphides (especially Indium, 0.005% in sulphide) was observed to be the primary cause of the observed RD savings by the Wash&Rec scenarios.
- **Human toxicity, cancer effects (HTc)**
 - Ranking (low impact < high impact):
Disp&Neutr < Wash&Rec < Aggregate
 - Aggregate:
The scenario provided net HTc impacts. These impacts were almost exclusively (~98% of the net impacts) coming from the potential leaching of Cr from the aggregates, which (as described in Section 2.5.3) was assumed to affect the groundwater compartment.
 - Wash&Rec:
The scenario provided net HTc impacts. The upstream production of hydrogen peroxide and the potential landfill emissions of Cr (leaching to groundwater) were the processes contributing the most to the observed net HTc impacts. In general, the observed net HTc impacts from Scenario Wash&Rec were lower than Scenario Aggregate, but because of the relatively large uncertainty behind the potential leaching of Cr (both from Scenario Aggregate and Wash&Rec) the actual ranking may be subjected to changes.

- **Human toxicity, non-cancer effects (HTnc)**
 - Ranking (low impact < high impact):
Disp&Neutr < Wash&Rec < Aggregate
 - Aggregate:
The scenario provided net HTnc impacts, which were primarily due to the potential leaching of Zn and As from the aggregates. The impacts from Zn and As contributed to ~71% and ~22%, respectively, of the impacts related to leaching.
 - Wash&Rec:
The scenario provided net HTnc impacts. The main impacting processes were the upstream production of electricity, auxiliary materials (mainly sodium hydroxide and hydrochloric acid) and heat (in the case of salt recovery). The main processes contributing to savings were the avoided production of zinc concentrate and virgin sodium chloride (i.e. de-icing agent, in the case of salt recovery).
In the case of salt recovery, the overall net HTnc impacts increased slightly relatively to the case of no salt recovery – mainly because of the relative contribution from the upstream emissions related with the production of heat (from the combustion of wood chips).
- **Ecotoxicity freshwater (EcoT)**
 - Ranking (low impact < high impact):
Disp&Neutr << Wash&Rec << Aggregate
 - Aggregate:
The scenario provided net EcoT impacts, which were mostly due to the potential leaching of Zn and Cr from the aggregates (which corresponded to ~75% and ~13%, respectively, of the net impacts).
 - Wash&Rec:
The scenario provided net EcoT impacts, which were about one order of magnitude lower than the impacts from Scenario Aggregate. The main impacting processes were the production of auxiliary materials (mainly hydrogen peroxide and hydrochloric acid) and the potential landfill emissions of Cr and Ni (through leaching to groundwater).
- **Eutrophication freshwater (EutrF)**
 - Ranking (low impact < high impact):
Wash&Rec_SaltRec < Wash&Rec_NoSalt ≈ Disp&Neutr < Aggregate
 - Aggregate:
The scenario provided net EutrF impacts, which were mostly due to the upstream production of auxiliary materials. In particular, the production of liquid CO₂ and cement accounted for nearly all of the auxiliary materials impacts, i.e. ~57% for liquid CO₂ and ~41% for cement.

- Wash&Rec:

The scenarios showed neutral to net EutrF savings, although the actual uncertainty of the results cannot exclude the case of net impacts in the case of Scenario Wash&Rec_NoSalt. The main processes contributing to savings were the avoided production of Zn concentrate and virgin sodium chloride (i.e. de-icing agent, in the case of salt recovery), whereas the most impacting process was the production of auxiliary materials (primarily sodium hydroxide and hydrogen peroxide).

- o **Eutrophication marine water (EutrM)**

- Ranking (low impact < high impact):

Disp&Neutr < Wash&Rec < Aggregate

- Aggregate:

The scenario provided net EutrM impacts, which were mostly due to the upstream production of auxiliary materials, in particular cement and liquid CO₂, which accounted for nearly all of the auxiliary materials impacts, i.e. ~70% for cement and ~20% for liquid CO₂.

- Wash&Rec:

The scenario provided net EutrM impacts. These impacts were slightly lower than for Scenario Aggregate. While many processes showed to have a noticeable effect on the results, the main impacting processes were the upstream production of auxiliary materials (mainly hydrogen peroxide and sodium hydroxide) and heat (from the combustion of wood chips), whereas the main processes contributing to savings were the avoided production of zinc concentrate and virgin sodium chloride (i.e. de-icing agent).

- o **Eutrophication terrestrial (EutrT)**

- Ranking (low impact < high impact):

Wash&Rec < Disp&Neutr < Aggregate

- Aggregate:

The scenario provided net EutrT impacts, which were mostly due to the upstream production of auxiliary materials, namely cement (~74%) and liquid CO₂ (~14%).

- Wash&Rec:

The Wash&Rec scenarios showed neutral to net EutrF savings, although the actual uncertainty of the results cannot exclude the case of net impacts. The main processes contributing to the savings were the avoided production of Zn concentrate and virgin sodium chloride (i.e. de-icing agent, in the case of salt recovery), whereas the most impacting processes were the upstream production of electricity and heat (from the combustion of wood chips).

○ **Particulate matter (PM)**

- Ranking (low impact < high impact):

Disp&Neutr < Aggregate < Wash&Rec

- Aggregate:

The scenario provided net PM impacts. These impacts were mainly due to the upstream production of auxiliary materials, namely cement (57%), liquid CO₂ (24%) and limestone (18%). The savings related to the avoided production of virgin gravel corresponded to roughly half of the auxiliary materials' impacts.

- Wash&Rec:

The scenario provided net PM impacts, which were generally a bit higher than for Scenario Aggregate. The main impacting processes were the production of auxiliary materials (mainly sodium hydroxide and hydrogen peroxide) and heat (from the combustion of wood chips), whereas the main process contributing to savings was the avoided production of sodium chloride (i.e. de-icing agent).

3.3. Uncertainty

3.3.1. Global sensitivity analysis

The main results of the uncertainty contribution analysis are presented in Figure 6, which reports the number of parameters needed to represent the full analytical uncertainty. Table A-7 lists the top five parameters contributing to most of the uncertainty, for each of the discussed impact categories.

In the case of Scenario Disp&Neutr, three parameters were sufficient to describe at least 89% of the full analytical uncertainty in all impact categories. These parameters were the amounts of waste acids used during the neutralisation process, the amounts of sodium hydroxide used during the treatment of wastewater and the lorry driving distance (from the incineration plant to the closes port).

In the case of Scenario Aggregate, three parameters were sufficient to describe at least 97% of the full analytical uncertainty in all impact categories. The actual parameters varied depending on the considered impact category. However, a few key parameters appeared to control the most of the uncertainty of multiple impact categories at the same time. These were the amounts of cement, limestone and liquid CO₂ used during the manufacturing process. In the case of the toxicity impact categories, more than 90% of the uncertainty could be described either by the leaching of Zn (HTnc and EcoT) or Cr (HTc).

In the case of Scenario Wash&Rec, three parameters were sufficient to describe at least 90% of the full analytical uncertainty in seven impact categories (i.e. GW, RD, RDfos, HTc, HTnc, EutrF and EutrT). In the case of PM, EcoT and EutrM, a few more parameters would be required to have a similar representation of the full analytical uncertainty. In general, a few key parameters appeared to control the most of the uncertainty of multiple impact categories at the same time. In the case of EutrF, EutrM, EutrT, HTnc, PM and RD, the key parameters were the amounts of acid scrubber water, hydrogen peroxide, hydrochloric acid, heat and substituted zinc concentrate. In the case of EcoT and HTc, the key parameters were the leaching of Cr and Ni. In the case of GW and RDfor, the key parameters were the amounts of hydrogen peroxide and substituted quicklime.

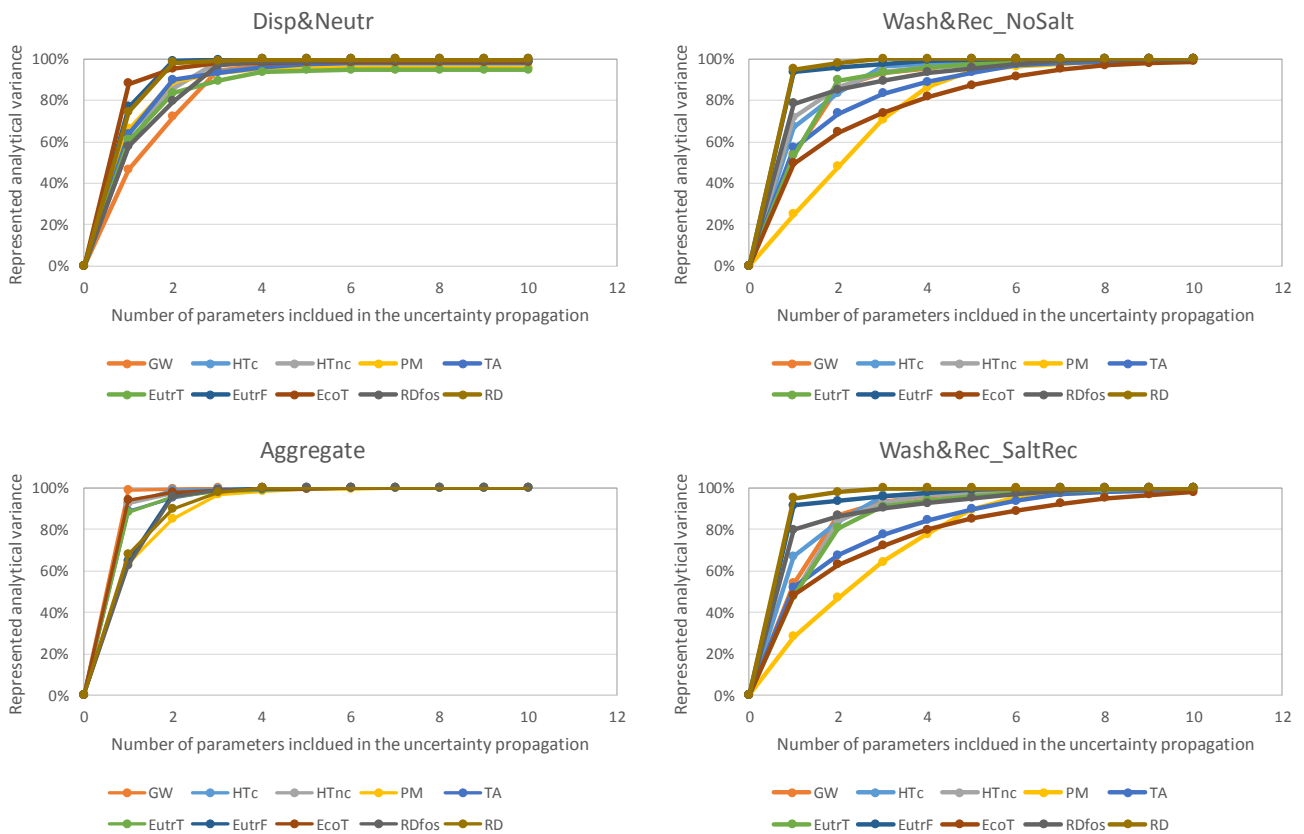

Figure 6. Percentage of the total analytical variance reached with a variable number of parameters included in the propagation for the three fly ash management scenarios. The lines represent the impact categories

4. CONCLUSIONS

- Scenario Disp&Neutr often presented the lowest burdens to the environment, but not necessarily. The Wash&Rec scenarios performed better in the case of following impact categories: RD, EutrF and EutrT (and GW, but only when salt recovery was included also).
- The Wash&Rec scenarios showed lower impacts (or higher savings) than Scenario Aggregate in the following impact categories: GW, RD, HTnc, EcoT, EutrF and EutrT (and EutrM, but only when salt recovery was included also). In the case of PM, Scenario Aggregate presented lower impacts than the Wash&Rec scenarios. In the case of HTc, the relatively large uncertainty behind the long-term release of Cr from the lightweight aggregates made it difficult to define a simple ranking across the scenarios, although the average net impacts observed for the Wash&Rec scenarios were lower than for Scenario Aggregate.
- The impacts from the Wash&Rec scenarios were generally slightly lower in the case of salts recovery, but they were very sensitive to the way that heat is assumed to be generated.
- The production of auxiliary materials had a relatively high impact to the individual impact categories, irrespective of the technology considered. On the other hand, the impacts from the considered transportation processes were often negligible.
- In the case of Wash&Rec scenarios, the avoided production of zinc concentrate, quicklime and sodium chloride (de-icing) induced relatively large savings across multiple impact categories. The production of natural gravel is a relatively low (environmental) impacting process compared with the production of zinc concentrate and quicklime. Accordingly, relatively lower savings were observed from the substitution of natural gravel in Scenario Aggregate.
- The toxicity impact categories (i.e. HTc, HTnc and EcoT) were the ones that showed the highest uncertainty in the results. In general, a large part of this uncertainty could be described by the uncertainty in leaching of a few key elements, i.e. Zn, Cr and Ni. If on one hand, the availability of more material-specific leaching data could provide a more accurate information on the potential leaching behaviour of both the aggregates and the washed fly ash, on the other hand, it is worth noting that the modelling of long-term emissions through leaching is intrinsically highly uncertain. Future long-term emissions depends on a variety of conditions – see for example the ash composition, the actual exposure to water, the leachate collection efficiency in the landfill, the potential interactions between the leachate and the soil, and the actual long-term management of waste products – which are difficult to predict *a priori*.

REFERENCES

- Allegrini, E., Butera, S., Kosson, D.S., Van Zomeren, A., Van der Sloot, H.A., Astrup, T.F., 2015. Life cycle assessment and residue leaching: The importance of parameter, scenario and leaching data selection. *Waste Manag.* 38, 474–485. doi:10.1016/j.wasman.2014.12.018
- ARC, 2019. Personal communication, February 2019, Jonas Nedenskov <jne@a-r-c.dk>.
- Astrup, T., 2008. Management of APC residues from W-t-E Plants - An overview of management options and treatment methods 116.
- Astrup, T., Dijkstra, J.J., Comans, R.N.J., van der Sloot, H., Christensen, T.H., 2006a. Geochemical modeling of leaching from MSWI air-pollution-control residues. *Environ. Sci. Technol.* 40, 3551–7. doi:10.1021/es052250r
- Astrup, T., Jakobsen, R., Christensen, T.H., Hansen, J.B., Hjelmar, O., 2006b. Assessment of long-term pH developments in leachate from waste incineration residues. *Waste Manag. Res.* 24, 491–502. doi:10.1177/0734242X06066963
- Astrup, T., Mosbaek, H., Christensen, T.H., 2006c. Assessment of long-term leaching from waste incineration air-pollution-control residues. *Waste Manag.* 26, 803–14. doi:10.1016/j.wasman.2005.12.008
- Birgisdóttir, H., 2005. Datakatalog RoadRes. A background to the development of a life cycle assessment tool for road construction and disposal of residues from waste (Et baggrundsmateriale til udvikling af et livscyklusvurderingsværktøj for vejbygning og disponering af restprod.
- Bisinella, V., Conradsen, K., Christensen, T.H., Astrup, T.F., 2016. A global approach for sparse representation of uncertainty in Life Cycle Assessments of waste management systems. *Int. J. Life Cycle Assess.* 21, 378–394. doi:10.1007/s11367-015-1014-4
- Bösch, M.E., Haupt, M., Hellweg, S., 2011. Ökobilanzielle Untersuchung der sauren Wäsche von KVA Flugasche in der Schweiz. ETH Zürich.
- Bühler, A., Schlumberger, S., 2010. Schwermetalle aus der Flugasche zurückgewinnen: Saure Flugaschenwäsche - FLUWA Verfahren, ein zukunftsweisendes Verfahren in der Abfallverbrennung, in: KVA- Rückstände in Der Schweiz – Der Rohstoff Mit Mehrwert (MSWI Residues in Switzerland – A Resource with Added Value). Swiss Federal Office for the Environment (FOEN), Bern, pp. 185–192.
- Carbon8 Aggregates Ltd, 2011. Carbon8 Aggregates Ltd standard for “Block Aggregate” Specification. Chatham Maritime.
- Clavreul, J., Baumeister, H., Christensen, T.H., Damgaard, A., 2014. An environmental assessment system for environmental technologies. *Environ. Model. Softw.* 60, 18–30. doi:10.1016/j.envsoft.2014.06.007
- Damgaard, A., Manfredi, S., Merrild, H., Stensøe, S., Christensen, T.H., 2011. LCA and economic evaluation of landfill leachate and gas technologies. *Waste Manag.* 31, 1532–1541. doi:10.1016/j.wasman.2011.02.027
- Di Gianfilippo, M., Costa, G., Pantini, S., Allegrini, E., Lombardi, F., Astrup, T.F., 2016. LCA of

- management strategies for RDF incineration and gasification bottom ash based on experimental leaching data. *Waste Manag.* 47, 285–298. doi:10.1016/j.wasman.2015.05.032
- Directive 2003/33/EC, 2003. Council Decision of 19 December 2002 establishing criteria and procedures for the acceptance of waste at landfills pursuant to article 16 of and Annex II to Directive 1999/31/EC.
- DMI, 2017. Klimadata Danmark ver. 4 (inkl. landstal). Kommunale og landets referenceværdier 2006-2015. Måned- og årsværdier for temperatur, nedbør og solskin. Kommunernes og landets generelle vejr og klima. Klimadata anvendt i ”Trap Danmark 6. udgave”. DMI rapport.
- EN 12457-4:2002, 2002. Characterisation of waste – Leaching – Compliance test for leaching of granular waste materials and sludges – Part 4: One stage batch test at a liquid to solid ratio of 10 L/kg for materials with particle size below 10 mm (without or with size reduction).
- European Commission, 2016. Energy, transport and GHG emissions Trends to 2050. EU Reference Scenario 2016. doi:10.2833/9127
- European Commission, 2011. Recommendations for Life Cycle Impact Assessment in the European context - based on existing environmental impact assessment models and factors. doi:10.2788/33030
- Fellner, J., Lederer, J., Purgar, A., Winterstetter, A., Rechberger, H., Winter, F., Laner, D., 2015. Evaluation of resource recovery from waste incineration residues - The case of zinc. *Waste Manag.* 37, 95–103. doi:10.1016/j.wasman.2014.10.010
- Gunning, P.J., Hills, C.D., Antemir, A., Carey, P.J., 2011. Secondary aggregate from waste treated with carbon dioxide. *Proc. Inst. Civ. Eng. - Constr. Mater.* 164, 231–239. doi:10.1680/coma.1000011
- He, P.-J., Zhang, H., Shao, L.-M., Lee, D.-J., 2006. Leaching of Carbonated Air Pollution Control Residues Using Compliance Leaching Tests. *J. Environ. Qual.* 35, 442. doi:10.2134/jeq2005.0312
- Laurent, A., Hauschild, M.Z., Golsteijn, L., Simas, M., Fontes, J., Wood, R., 2013. Deliverable 5.2: Normalisation factors for environmental, economic and socio- economic indicators. *Dev. Appl. a Stand. Methodol. Prospect. Sustain. Assess. Technol.*
- Li, X., Bertos, M.F., Hills, C.D., Carey, P.J., Simon, S., 2007. Accelerated carbonation of municipal solid waste incineration fly ashes. *Waste Manag.* 27, 1200–1206. doi:10.1016/j.wasman.2006.06.011
- Miljødirektoratet, 2014. Oversendelse av en rett tillatelse - NOAH Langøya.
- Miljøstyrelsen, 2015. Sambehandling af RGA og scrubber væske fra forbrændingsanlæg med HALOSEP processen. Miljøprojekt nr. 1648, 2015.
- NGI, 2018. Deponi for nøytralisert og stabilisert uorganisk farlig avfall i Dalen gruve , Brevik.
- NGI, 2004. NOAH - Langøya Miljøriskovurdering av deponiene på Langøya.
- Polettini, A., Pomi, R., Trinci, L., Muntoni, A., Lo Mastro, S., 2004. Engineering and environmental properties of thermally treated mixtures containing MSWI fly ash and low-cost additives. *Chemosphere* 56, 901–910. doi:10.1016/j.chemosphere.2004.05.004

- Prognos AG, RSP Riemann Sonnenschein & Partner GmbH, Jochen Schulte, 2012. Outlook for underground waste management in Germany. Verband der Kali- und Salzindustrie e. V. (VKS), Verband Bergbau, Geologie und Umwelt e. V. (VBGU).
- Quina, M.J., Santos, R.C., Bordado, J.C., Quinta-Ferreira, R.M., 2008. Characterization of air pollution control residues produced in a municipal solid waste incinerator in Portugal. *J. Hazard. Mater.* 152, 853–869. doi:10.1016/j.jhazmat.2007.07.055
- Schlumberger, S., Schuster, M., Ringmann, S., Koralewska, R., 2007. Recovery of high purity zinc from filter ash produced during the thermal treatment of waste and inerting of residual materials. *Waste Manag. Res.* 25, 547–555. doi:10.1177/0734242X07079870
- Wang, L., Chen, Q., Jamro, I.A., Li, R., Li, Y., Li, S., Luan, J., 2016. Geochemical modeling and assessment of leaching from carbonated municipal solid waste incinerator (MSWI) fly ash. *Environ. Sci. Pollut. Res.* 23, 12107–12119. doi:10.1007/s11356-016-6320-2
- Wernet, G., Bauer, C., Steubing, B., Reinhard, J., Moreno-Ruiz, E., Weidema, B., 2016. The ecoinvent database version 3 (part I): overview and methodology. [WWW Document]. *Int. J. Life Cycle Assessment*, [online].
- Zhang, H., He, P.J., Shao, L.M., Lee, D.J., 2008. Temporary stabilization of air pollution control residues using carbonation. *Waste Manag.* 28, 509–517. doi:10.1016/j.wasman.2007.02.005
- Zhang, Y., Cetin, B., Likos, W.J., Edil, T.B., 2016. Impacts of pH on leaching potential of elements from MSW incineration fly ash. *Fuel* 184, 815–825. doi:10.1016/j.fuel.2016.07.089

A. APPENDIX

Table A-1. Compositions of the MSWI fly ash, the liquid residues from the acid scrubber and the sulphuric acid residues, expressed in mg/kg. The standard deviation represents the minimum distance between the highest observation point from the weighted average and the lowest observation point from the weighted average.

	MSWI fly ash		Acid scrubber water		Sulphuric acid residues	
	Weighted average mg/kg	2xStand.Dev mg/kg	Weighted average mg/kg	2xStand.Dev mg/kg	Weighted average mg/kg	2xStand.Dev mg/kg
Ag	20	± 10				
Al	26000	± 17000	2	± 1	287	± 16
As	280	± 230			0.08	± 0.02
Ba	1300	± 400	400	± 400	0.07	± 0.04
Bi	90	±				
Ca	145000	± 59000	1380	± 1360		
Cd	250	± 210	0.3	± 0.3	0.02	± 0.01
Cl	67000	± 27000	50000	± 10000		
Co	20	±			15	± 2
Cr	510	± 300	0.1	± 0.1	231	± 12
Cu	2300	± 1400	2	± 1	1.8	± 0.2
F	1400	± 300				
Fe	11000	± 1000	10	± 10	32758	± 13751
Hg	3	± 2	1.5	± 0.5	0.000020	± 0.000002
K	50000	± 34000	120	± 70		
Li	4600	± 4500	5	± 5		
Mg	12000	± 5000	250	± 140		
Mn	700	± 700	30	± n.a.	616	± 34
Mo	20	± 10			0.34	± 0.11
Na	51000	± 27000	300	± 140		
Ni	70	± 30			22.3	± 2.3
P	6000	± 1000	9	± 8		
Pb	6000	± 5000	9	± 2	1.18	± 0.37
Rb	160	± 10				
S	50000	± 29000	270	± 60	95385	± 9539
Sb	1000	± 600	0.5	± 0.5	3.1	± 1.0
Sc	2	±				
Se	30	±				
Si	60000	± 19000	50	± 10		
Sn	1300	± 500	1	± n.a.	0.21	± 0.07
Sr	400	± 300	30	± 20		
Ti	8000	± 1000	1	± n.a.	2678	± 404
TOC	9000	±				
V	50	± 20			444	± 24
W	90	±				
Y	10	±				
Zn	25000	± 14000	50	± 20	21	± 8
Zr	70	± 10				

Table A-2 Consumption of reagents by Amager Bakke to treat the acid scrubber water (ARC, 2019). [wastew.: wastewater]

- I): the same reagents and amounts are assumed to be used to treat the wastewater flows in Scenarios Disp&Neutr and Wash&Rec. The assumed uncertainty aims to cover potential variability in the wastewater composition;
- II) not used in this LCA because of lack of LCI data describing the upstream production of this reagent

Reagent	Amount	Unit	Assumed Uncertainty	Assumed Distribution	Comment
Sodium Hydroxide (25%)	7.81	kg/m ³ wastew.	± 50%	UD	I)
TMT-15	0.2	kg/m ³ wastew.	± 50%	UD	I)
FeCl ₃ (40%)	0.1	kg/m ³ wastew.	± 50%	UD	I)
Hydrochloric Acid	1.33	kg/m ³ wastew.	± 50%	UD	I)
Quicklime	0.67	kg/m ³ wastew.	± 50%	UD	I)
Anti-Scalant	0.095	kg/m ³ wastew.	± 50%		II)

Table A-3. Net leaching data used to model the release from lightweight aggregates (Scenario Aggregate). All the values are expressed in mg/kg and based on L/S 10 L/kg batch leaching tests. The presented leaching data have already been subtracted of the expected leaching from natural gravel (Birgisdóttir, 2005), which would have been otherwise used – see Section 2.5.3 for more details.

- Minimum value: represents the case where the aggregates release as much as half of their maximum leaching requirements (Carbon8 Aggregates Ltd, 2011).
- Maximum value: represents the case where the aggregates are assumed to be crushed and their release is calculated as the sum between the maximum leaching requirements defined for Carbon8 aggregates (Carbon8 Aggregates Ltd, 2011) and the average releases observed for carbonated MSWI fly ash during batch leaching tests carried out at the L/S 10 L/kg (Astrup et al., 2006c, 2006a; He et al., 2006; Li et al., 2007; Wang et al., 2016; Zhang et al., 2008, 2016).

	min mg/kg aggregate	max mg/kg aggregate	Assumed distribution
As	2.3E-07	4.9E-07	UD
Ba	9.8E-06	2.2E-05	UD
Cd	8.1E-09	2.6E-06	UD
Cr	7.4E-07	2.6E-06	UD
Cu	7.3E-08	9.0E-07	UD
Mo	5.0E-07	1.0E-06	UD
Ni	1.9E-07	1.8E-06	UD
Pb	2.5E-07	5.6E-06	UD
Se	5.0E-08	1.0E-07	UD
Sb	3.0E-08	7.5E-07	UD
Zn	1.7E-06	5.2E-05	UD
Cl	3.7E-02	1.3E-01	UD
SO₄²⁻	2.1E-03	6.7E-03	UD
Hg*	5.0E-09	8.7E-08	UD

*) as no leaching criteria for Hg is defined for the Carbon8 aggregates, this was estimated based on the leaching criteria defined for landfills of inert waste (Directive 2003/33/EC, 2003)

Table A-4 Parameters used during L/S ratio calculations, as a function of the landfill age. [* the expected L/S ratio in the case of resins was calculated using the same parameters as for fly ash; ND: normal distribution; UD: uniform distribution].

l: infiltration; *P*: precipitation; ρ : bulk density; *h*: height.

Parameter	Unit	Fly Ash* in landfill 0 – 2 y	Assumed distribution	Fly Ash* in landfill 2 – 100 y	Assumed distribution	Fly Ash* in landfill 100 – 500 y	Assumed distribution
<i>l</i>	%	(66 ± 5) ^a	(ND) ^b	22 ^a ± 5 ^b	(ND) ^b	22 ^b ± 5 ^b	(ND) ^b
<i>P</i>	mm ⁻¹ · year ⁻¹	790 ^c ± 50 ^b	(ND) ^b	790 ^b ± 50 ^b	(ND) ^b	790 ^b ± 50 ^b	(ND) ^b
ρ	kg · m ⁻³	660 ^d – 1010 ^e	(UD) ^b	660 ^d – 1010 ^e	(UD) ^b	660 ^d – 1010 ^e	(UD) ^b
<i>h</i>	m	10 ^b		10 ^b		10 ^b	

a: Di Gianfilippo et al. (2016); *b*: assumed value; *c*: based on DMI (2017); *d*: Quina et al. (2008); *e*: Polettini et al. (2004); *f*: based on Allegrini et al. (2015).

Table A-5. Composition of the leachate escaping the landfill collection system (the assumed collection efficiencies are reported in Section 2.5.3) in each of the considered time periods: i.e. 2y (the landfill cell is filled up and closed), 18y, 20y, 30y_I (aftercare period), 30_II, 400 years. The overall leachate composition over the 500y time horizon should be intended as the sum of 2y, 18y, 20y, 30y_I, 30y_II and 400y.

Leaching data were extrapolated from column experiments based on washed fly ash from HALOSEP technology (Miljøstyrelsen, 2015). Column leaching data were interpolated, by means of least squares fitting using a logarithmic function, and extrapolated at the L/S ratios that the ashes are expected to experience within the considered time periods. [UD: uniform distribution]

	min	max	Assumed
	mg/kg TS	mg/kg TS	distribution
L_As2y	4.3E-05	2.7E-04	UD
L_As18y	1.4E-04	6.8E-04	UD
L_As20y	1.2E-03	5.9E-03	UD
L_As30y_I	3.4E-03	1.5E-02	UD
L_As30y_II	1.3E-02	5.7E-02	UD
L_As400y	6.9E-02	2.5E-01	UD
L_Ba2y	9.8E-04	2.6E-03	UD
L_Ba18y	1.8E-03	4.7E-03	UD
L_Ba20y	1.6E-02	4.1E-02	UD
L_Ba30y_I	3.6E-02	9.3E-02	UD
L_Ba30y_II	1.3E-01	3.4E-01	UD
L_Ba400y	4.2E-01	1.1E+00	UD
L_Cd2y	2.6E-07	2.9E-05	UD
L_Cd18y	9.2E-07	3.0E-05	UD
L_Cd20y	8.2E-06	2.9E-04	UD
L_Cd30y_I	2.4E-05	5.6E-04	UD
L_Cd30y_II	9.2E-05	2.0E-03	UD
L_Cd400y	5.5E-04	3.8E-03	UD
L_Cr2y	1.2E-04	1.1E-02	UD
L_Cr18y	2.3E-04	1.4E-02	UD
L_Cr20y	2.0E-03	1.3E-01	UD
L_Cr30y_I	4.8E-03	2.6E-01	UD
L_Cr30y_II	1.7E-02	9.3E-01	UD
L_Cr400y	5.7E-02	2.2E+00	UD
L_Cu2y	8.9E-06	3.9E-05	UD
L_Cu18y	2.3E-05	9.9E-05	UD
L_Cu20y	2.0E-04	8.6E-04	UD
L_Cu30y_I	5.1E-04	2.2E-03	UD
L_Cu30y_II	1.9E-03	8.3E-03	UD
L_Cu400y	8.4E-03	3.6E-02	UD
L_Hg2y	5.1E-07	2.4E-04	UD
L_Hg18y	1.2E-06	4.8E-04	UD
L_Hg20y	1.0E-05	4.2E-03	UD
L_Hg30y_I	2.5E-05	9.9E-03	UD

L_Hg30y_II	9.1E-05	3.6E-02	UD
L_Hg400y	3.5E-04	1.2E-01	UD
L_Mo2y	2.3E-03	3.3E-02	UD
L_Mo18y	3.0E-03	3.7E-02	UD
L_Mo20y	2.7E-02	3.6E-01	UD
L_Mo30y_I	5.5E-02	6.9E-01	UD
L_Mo30y_II	2.0E-01	2.5E+00	UD
L_Mo400y	4.5E-01	5.0E+00	UD
L_Ni2y	8.0E-06	8.2E-03	UD
L_Ni18y	2.1E-05	2.2E-02	UD
L_Ni20y	1.8E-04	1.9E-01	UD
L_Ni30y_I	4.8E-04	4.9E-01	UD
L_Ni30y_II	1.8E-03	1.8E+00	UD
L_Ni400y	8.0E-03	8.2E+00	UD
L_Pb2y	2.8E-06	2.9E-05	UD
L_Pb18y	9.2E-06	7.6E-05	UD
L_Pb20y	8.2E-05	6.6E-04	UD
L_Pb30y_I	2.3E-04	1.7E-03	UD
L_Pb30y_II	8.9E-04	6.5E-03	UD
L_Pb400y	5.0E-03	2.9E-02	UD
L_Sb2y	2.1E-05	2.1E-05	UD
L_Sb18y	5.9E-05	5.9E-05	UD
L_Sb20y	5.1E-04	5.1E-04	UD
L_Sb30y_I	1.4E-03	1.4E-03	UD
L_Sb30y_II	5.2E-03	5.2E-03	UD
L_Sb400y	2.5E-02	2.5E-02	UD
L_Se2y	5.0E-04	1.7E-03	UD
L_Se18y	5.8E-04	1.6E-03	UD
L_Se20y	5.5E-03	1.6E-02	UD
L_Se30y_I	1.1E-02	2.9E-02	UD
L_Se30y_II	3.8E-02	1.0E-01	UD
L_Se400y	7.9E-02	1.8E-01	UD
L_Zn2y	2.9E-05	2.8E-04	UD
L_Zn18y	8.8E-05	2.6E-04	UD
L_Zn20y	7.7E-04	2.6E-03	UD
L_Zn30y_I	2.1E-03	4.8E-03	UD
L_Zn30y_II	8.1E-03	1.7E-02	UD
L_Zn400y	2.9E-02	4.2E-02	UD

Table A-6 List of the Life Cycle Inventory database Ecoinvent v 3.5 processes used (Wernet et al., 2016), all using the system model “Substitution, consequential, long-term”. [Location Data: GLO: Global; RER: Europe; CH: Switzerland; DK: Denmark; NO: Norway]

DESCRIPTION	PROCESS
Transportation	
Lorry	market for transport, freight, lorry , 32 metric ton, EURO5, RER, 2018
Maritime tanker	market for transport, freight, sea, transoceanic tanker, GLO, 2018
Wastewater treatment	
NaOH 25%	market for sodium hydroxide, without water, in 50% solution state, GLO, 2018
TMT-15	market for chemical, organic, GLO, 2018
HCl 30%	market for hydrochloric acid, without water, in 30% solution state, RER, 2018
FeCl ₃ 40%	market for iron(III) chloride, without water, in 14% iron solution state, GLO, 2018
Polyelectrolyte	market for chemicals, inorganic, GLO, 2018
CaO 95%	market for quicklime, milled, packed, RER, 2018
Substituted materials	
Limestone	market for limestone, crushed, washed, CH, 2018
Gravel	market for gravel, crushed, CH, 2018
Quicklime	market for quicklime, milled, packed, RER, 2018
Zn concentrate	market for zinc concentrate - GLO
Sodium Chloride	market for sodium chloride, powder, GLO, 2018
Disp&Neutr	
Electricity	market for electricity, medium voltage, NO, 2018
Quicklime	market for quicklime, milled, packed, RER, 2018
Use of diesel by machineries	diesel, burned in building machine, GLO, 2018
Water	none - Assumption: use of rainwater
Aggregate	
Electricity	market for electricity, medium voltage, DK, 2018
Water	market for tap water, Europe without Switzerland, 2018
CO ₂ liq	market for carbon dioxide, liquid, RER, 2018
Cement	market for cement, Portland, Europe without Switzerland, 2018
Limestone	market for limestone, crushed, washed, CH, 2018
Wash&Rec	
Electricity	market for electricity, medium voltage, DK, 2018
Heat	heat production, at heat pump 30kW, allocation exergy, CH, 2018 (1) heat production, hardwood chips from forest, at furnace 5000kW, state-of-the-art 2014, CH, 2018
HCl (30%)	market for hydrochloric acid, without water, in 30% solution state, RER, 2018
H ₂ O ₂ (50%)	market for hydrogen peroxide, without water, in 50% solution state, RER, 2018
NaOH	market for sodium hydroxide, without water, in 50% solution state, GLO, 2018
Water	none - Assumption: use of process water
Landfill	process-specific burdens, slag landfill, Europe without Switzerland, 2018
Treatment of collected leachate	treatment of wastewater, average, capacity 1.6E8l/year - CH

Table A-7 Top five parameters contributing to most of the analytical uncertainty accompanied by their relative percentage contribution (%Unc). The letters “T_”, “S_” and “L_” at the beginning of the parameter’s name indicates whether this parameter is describing the potential variability in the operation conditions of the fly ash treatment technology (i.e. “T_”; e.g. amounts of auxiliary materials), in scenario conditions (i.e. “S_”; e.g. transportation distances) and in leaching releases (i.e. “L_”), respectively.

[GW: Climate change; HTc: Human toxicity, cancer effects; HTnc: Human toxicity, non-cancer effects; PM: Particulate matter; EutrT: Eutrophication Terrestrial; EutrF: Eutrophication Freshwater; EutrM: Eutrophication Marine; EcoT: Ecotoxicity freshwater; RDfos: Depletion of abiotic resources, fossil; RD: Depletion of abiotic resources, minerals and metals]

Disp&Neutr		Aggregate		Wash&Rec_NoSalt		Wash&Rec_SaltRec	
	%Unc		%Unc		%Unc		%Unc
GW		GW		GW		GW	
1 T_NOAH_NaOH_25	46.7%	T_AggrManuf_Cement	98.8%	T_Fluwa_CaO95	53.7%	T_Fluwa_CaO95	54.0%
2 S_FA_lorry	25.3%	S_ConcrManuf_gravel	0.9%	T_Fluwa_H2O250	32.5%	T_Fluwa_H2O250	32.7%
3 T_NOAH_SulfAcid	22.2%	S_FlyAsh_transp	0.1%	T_Fluwa_HCl30	6.8%	T_Fluwa_HCl30	6.8%
4 T_NOAH_diesel	2.9%	T_AggrManuf_Limestone	0.1%	T_Fluwa_scrub_liq	2.6%	S_Fluwa_Zn_concentr	2.6%
5 T_NOAH_H2O	0.4%	T_AggrManuf_CO2	0.0%	S_Fluwa_Zn_concentr	2.6%	T_Fluwa_scrub_liq	1.6%
HTc		HTc		HTc		HTc	
1 T_NOAH_NaOH_25	58.1%	L_C8_max_Cr	92.7%	L_Cr400y	67.1%	L_Cr400y	67.1%
2 T_NOAH_SulfAcid	30.8%	T_AggrManuf_Limestone	6.1%	T_Fluwa_H2O250	16.5%	T_Fluwa_H2O250	16.5%
3 S_FA_lorry	4.7%	T_AggrManuf_Cement	0.5%	L_Cr30y_II	12.6%	L_Cr30y_II	12.6%
4 T_NOAH_electr	2.3%	T_AggrManuf_H2O	0.5%	T_Fluwa_scrub_liq	1.6%	T_Fluwa_scrub_liq	1.5%
5 T_NOAH_H2O	1.8%	T_AggrManuf_CO2	0.1%	L_Cr30y_I	1.0%	L_Cr30y_I	1.0%
HTnc		HTnc		HTnc		HTnc	
1 T_NOAH_NaOH_25	64.5%	L_C8_max_Zn	92.7%	S_Fluwa_Zn_concentr	71.6%	T_salt_heat	48.2%
2 T_NOAH_SulfAcid	21.1%	T_AggrManuf_Limestone	4.5%	T_Fluwa_scrub_liq	14.7%	S_Fluwa_Zn_concentr	36.2%
3 S_FA_lorry	13.2%	L_C8_max_As	1.2%	T_Fluwa_HCl30	7.6%	T_Fluwa_scrub_liq	8.5%
4 T_NOAH_electr	0.4%	T_AggrManuf_Cement	1.0%	T_Fluwa_electr	1.9%	T_Fluwa_HCl30	3.8%
5 T_NOAH_H2O	0.2%	T_AggrManuf_H2O	0.4%	T_H2O	1.4%	T_Fluwa_electr	1.0%
PM		PM		PM		PM	
1 T_NOAH_NaOH_25	66.1%	T_AggrManuf_Cement	63.7%	T_Fluwa_H2O250	25.0%	T_salt_heat	28.2%
2 T_NOAH_SulfAcid	22.7%	S_ConcrManuf_gravel	21.6%	T_Fluwa_HCl30	23.0%	T_Fluwa_H2O250	18.8%
3 S_FA_lorry	4.5%	T_AggrManuf_CO2	11.6%	T_Fluwa_scrub_liq	22.7%	T_Fluwa_HCl30	17.3%
4 T_NOAH_diesel	1.9%	S_FlyAsh_transp	1.5%	S_Fluwa_Zn_concentr	15.5%	T_Fluwa_scrub_liq	13.5%
5 S_FA_sea	0.3%	T_AggrManuf_Electr	0.9%	T_Fluwa_NaOH50	8.2%	S_Fluwa_Zn_concentr	11.7%
EutrM		EutrM		EutrM		EutrM	
1 T_NOAH_NaOH_25	30.3%	T_AggrManuf_Cement	87.5%	S_Fluwa_Zn_concentr	65.4%	S_Fluwa_Zn_concentr	51.1%
2 T_NOAH_SulfAcid	21.8%	T_AggrManuf_CO2	6.7%	T_Fluwa_H2O250	9.3%	T_salt_heat	22.9%
3 T_NOAH_diesel	19.9%	S_ConcrManuf_gravel	5.0%	T_Fluwa_HCl30	9.1%	T_Fluwa_H2O250	7.3%
4 S_FA_lorry	13.6%	S_FlyAsh_transp	0.4%	T_Fluwa_scrub_liq	9.0%	T_Fluwa_HCl30	7.1%
5 T_NOAH_H2O	2.4%	T_AggrManuf_Electr	0.2%	T_Fluwa_CaO95	2.4%	T_Fluwa_scrub_liq	5.9%
EutrT		EutrT		EutrT		EutrT	
1 T_NOAH_NaOH_25	60.8%	T_AggrManuf_Cement	88.5%	T_Fluwa_HCl30	53.2%	T_Fluwa_HCl30	47.8%
2 T_NOAH_SulfAcid	22.6%	S_ConcrManuf_gravel	7.1%	S_Fluwa_Zn_concentr	36.5%	S_Fluwa_Zn_concentr	32.8%
3 T_NOAH_diesel	6.0%	T_AggrManuf_CO2	3.0%	T_Fluwa_scrub_liq	3.6%	T_salt_heat	10.4%
4 S_FA_lorry	4.3%	T_AggrManuf_Electr	0.5%	T_Fluwa_H2O250	2.4%	T_Fluwa_scrub_liq	3.0%
5 T_NOAH_H2O	0.7%	S_FlyAsh_transp	0.4%	T_Fluwa_NaOH50	1.9%	T_Fluwa_H2O250	2.1%
EutrF		EutrF		EutrF		EutrF	
1 T_NOAH_NaOH_25	76.9%	T_AggrManuf_CO2	64.5%	S_Fluwa_Zn_concentr	93.6%	S_Fluwa_Zn_concentr	91.7%
2 T_NOAH_SulfAcid	22.2%	T_AggrManuf_Cement	32.2%	T_Fluwa_HCl30	2.2%	T_Fluwa_HCl30	2.1%
3 S_FA_lorry	0.4%	S_ConcrManuf_gravel	2.4%	T_H2O	2.0%	T_H2O	2.0%
4 T_NOAH_electr	0.3%	T_AggrManuf_Electr	0.9%	T_Fluwa_H2O250	1.5%	T_salt_heat	1.9%
5 T_NOAH_H2O	0.1%	S_FlyAsh_transp	0.1%	T_Fluwa_NaOH50	0.6%	T_Fluwa_H2O250	1.4%
EcoT		EcoT		EcoT		EcoT	
	%Unc		%Unc		%Unc		%Unc

1	S_FA_lorry	88.0%	L_C8_max_Zn	94.0%	L_Cr400y	49.4%	L_Cr400y	48.3%
2	T_NOAH_NaOH_25	7.2%	T_AggrManuf_Limestone	3.9%	L_Ni400y	15.1%	L_Ni400y	14.7%
3	T_NOAH_SulfAcid	3.0%	L_C8_max_Cr	1.0%	L_Cr30y_II	9.3%	L_Cr30y_II	9.1%
4	T_NOAH_electr	0.1%	L_C8_max_Sb	0.4%	T_Fluwa_HCl30	7.7%	T_Fluwa_HCl30	7.6%
5	T_NOAH_HCl	0.1%	T_AggrManuf_Cement	0.4%	T_Fluwa_H2O250	5.8%	T_Fluwa_H2O250	5.6%
	RDfos	%Unc	RDfos	%Unc	RDfos	%Unc	RDfos	%Unc
1	T_NOAH_NaOH_25	57.7%	T_AggrManuf_CO2	62.6%	T_Fluwa_H2O250	78.4%	T_Fluwa_H2O250	79.7%
2	T_NOAH_SulfAcid	21.8%	T_AggrManuf_Cement	33.4%	T_Fluwa_CaO95	6.6%	T_Fluwa_CaO95	6.7%
3	S_FA_lorry	17.4%	S_ConcrManuf_gravel	3.0%	T_Fluwa_scrub_liq	4.5%	S_Fluwa_Zn_concentr	3.8%
4	T_NOAH_diesel	1.6%	S_FlyAsh_transp	0.6%	S_Fluwa_Zn_concentr	3.8%	T_Fluwa_scrub_liq	2.5%
5	T_NOAH_H2O	0.2%	T_AggrManuf_Limestone	0.3%	T_Fluwa_HCl30	2.3%	T_Fluwa_HCl30	2.4%
	RD	%Unc	RD	%Unc	RD	%Unc	RD	%Unc
1	T_NOAH_NaOH_25	74.5%	S_ConcrManuf_gravel	68.1%	S_Fluwa_Zn_concentr	95.0%	S_Fluwa_Zn_concentr	95.0%
2	T_NOAH_SulfAcid	23.6%	T_AggrManuf_Limestone	22.0%	T_Fluwa_scrub_liq	2.9%	T_Fluwa_scrub_liq	2.9%
3	S_FA_lorry	0.8%	T_AggrManuf_CO2	7.9%	T_H2O	2.1%	T_H2O	2.1%
4	T_NOAH_HCl	0.8%	T_AggrManuf_H2O	1.9%	T_Fluwa_HCl30	0.0%	T_Fluwa_HCl30	0.0%
5	T_NOAH_diesel	0.0%	T_AggrManuf_Cement	0.2%	T_Fluwa_H2O250	0.0%	T_Fluwa_H2O250	0.0%

B. APPENDIX

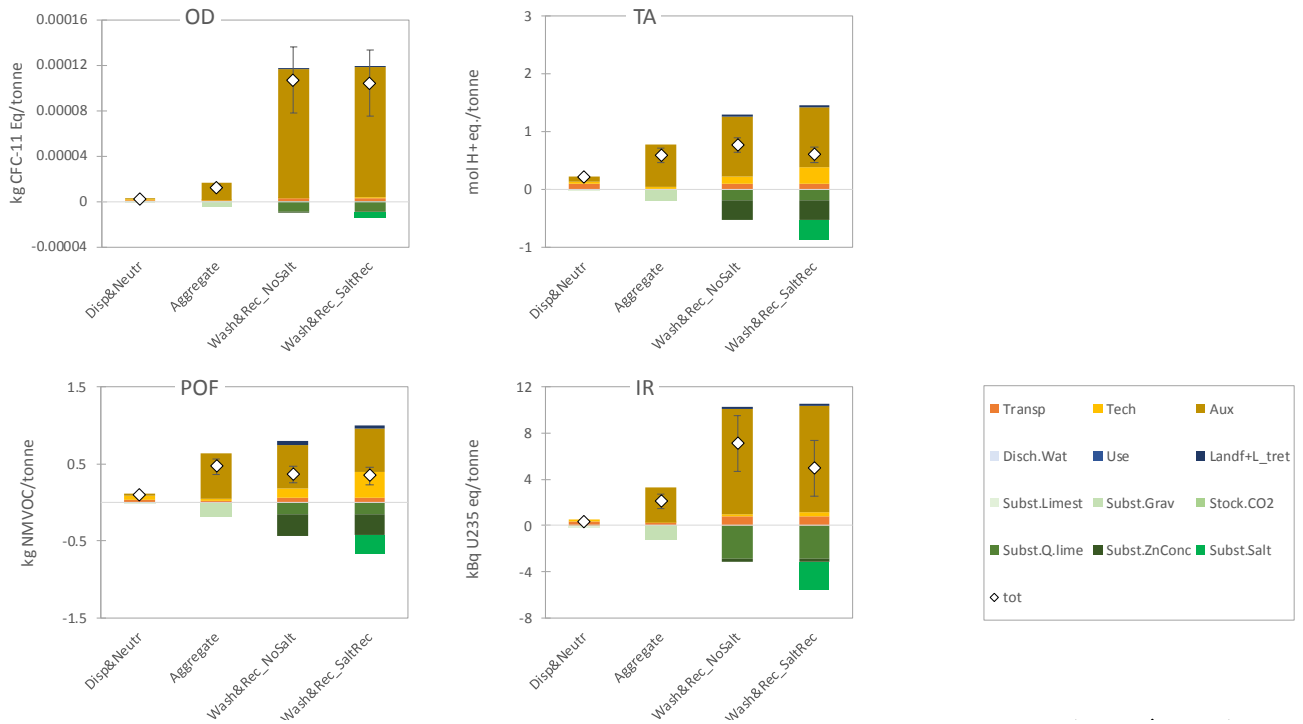

Figure B-1. Characterised impacts, for the impact categories not presented in Sections 3.2 and 3.3, of the four fly ash management scenarios. Negative values represent environmental savings (i.e. benefits), whereas positive values represent loads (i.e. impacts) to the environment. The net environmental impacts related to the individual scenarios are represented with a white diamond, accompanied by its standard deviation. [OD: Ozone depletion; IR: Ionising radiation human health; POF: Photochemical ozone formation, human health; TA: Terrestrial acidification]

